

Teslameters and FP Series Hall Probes



F71 Multi-Axis Teslameter

F41 Single-Axis Teslameter

FP Series Hall Probes

F41 and F71 Teslameters

F71 Multi-axis teslameter

F41 Single-axis teslameter

Perfect for measuring magnetic fields in a wide variety of applications, the new Lake Shore Cryotronics F71 and F41 teslameters with FP Series probes offer a new level of precision, convenience, and dependability.



Features

- TruZero™ technology eliminates the need to re-zero probes
- Touchscreen interface is instantly familiar to smartphone owners
- TiltView™ display makes the instruments easy to use whether bench- or rack-mounted
- Smaller, ultra-thin Hall sensor active areas for improved accuracy
- Multiple probe types to suit your application



Measure confidently



TruZero™ technology eliminates errors that plague magnetic field measurements, allowing you to take measurements without probe zeroing worries



New 2Dex™ Hall sensor probes take more accurate measurements with smaller active areas and better linearity performance than previous generation sensors



Temperature and field built in to produce field readings with great accuracy over a wide range of operating conditions

Operate easily



Uncluttered touchscreen using icons, gestures, and navigation techniques familiar to any smartphone user



The TiltView™ display is comfortable to see and operate, providing an improved touchscreen experience



Take accurate measurements sooner with quality low-temperature coefficient electronics that eliminate warm-up times



Lightweight and durable handheld probes for quick and convenient measurements

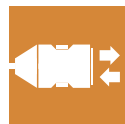

Swap out probes fast and hassle-free with the new unified quick-release connector with built-in calibration data

Integrate conveniently



Rack-mountable, with the ability to place other similarly sized instruments next to the teslameter



Fixture-mountable probes with machined aluminum handles and alignment features for easy attachment

Both teslameters offer modern connectivity choices for seamless system integration, including:



USB



Ethernet



GPIB (optional)

Industry standard SCPI communication library available along with LabVIEW™ and IVI drivers.

Measure confidently

Smaller active areas

FP Series probes feature 2Dex™ Hall sensors with significantly smaller active areas than in previous generation products. This results in improved spatial resolution and reduced signal averaging, useful when measuring fields close to a source where field gradients can be extreme.

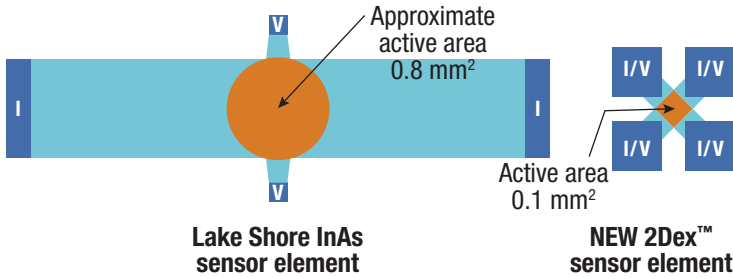

Temperature compensation

Hall effect sensors have several characteristics that vary with temperature, resulting in Hall voltage levels that can change slightly with temperature changes. The 2Dex™ sensors used in FP Series probes are inherently stable with temperature, however, this can be improved further with active temperature compensation.

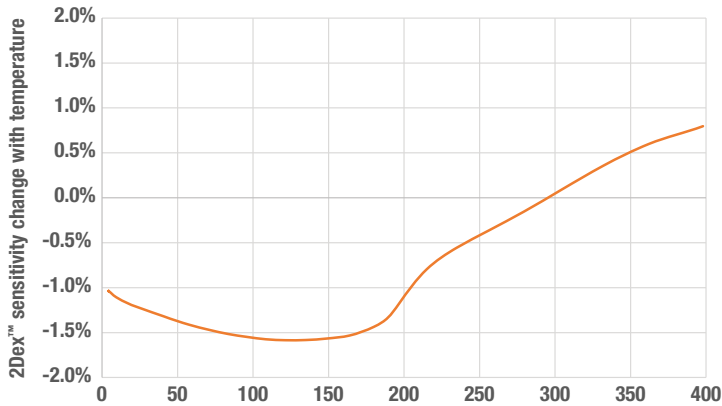

An integrated temperature sensor at the tip of every probe relays temperature data to the teslameter. These readings are used to determine temperature offsets and compensate for them over the standard workplace ambient temperature ranges.

Better 3-axis measurements

2Dex™ 3-axis magnetic sensors have been designed to maximize orthogonality between x, y, and z sensor elements, resulting in more accurate vector magnitude measurements when field direction is unknown or changing.

Operate easily

As easy to use as your smartphone

Made for the way you work today, the F71 and F41 teslameters feature an uncluttered touch display with a unique TiltView™ screen, presenting a natural and engaging user interface.



With no confusing buttons or long learning curves, these teslameters are simple and intuitive to operate. You will quickly recognize the icons, gestures, and menu styles that follow familiar smartphone technology standards.

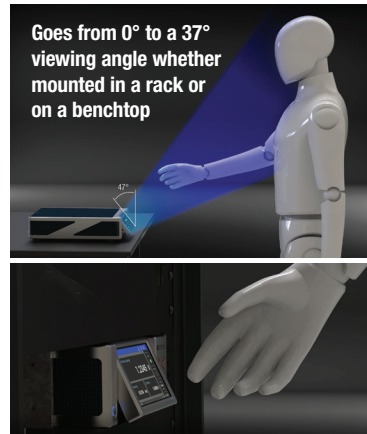

The large 5-inch capacitive touchscreen allows measurements to be displayed in clear, easily distinguishable fonts, making it possible to easily read in situations when your instrumentation is located some distance from where you are taking measurements.

Viewing angle is a critical parameter when interacting with a touchscreen.

Registering accurate presses can be difficult if the viewer is not aligned correctly with the screen.

TiltView™ allows the viewer to manually adjust the viewing angle of the screen, resulting in a better view and increased accuracy when interacting with the touchscreen.

The tilt mechanism uses the perfect amount of stiffness to allow movement when desired, but stays in place when pressing and swiping on the screen.

Never zero your probe again

Offset errors in typical Hall probes occur for several reasons:

- Thermoelectric effects, which cause the offset to change with temperature.
- Imperfect contact placement geometry on the sensor, which creates so-called “misalignment voltage” errors that are harder to correct for.

These errors result in probe “drift,” impacting measurement repeatability.

Typical Hall probes must be regularly placed in a **zero-gauss chamber** to zero out offsets that develop over time.



TruZero™ technology

Lake Shore’s TruZero™ technology eliminates the need to perform these frequent zeroing operations, saving time and ensuring that measurements are always accurate.

This multi-part technology is accomplished through multiple mechanisms:

- 1 2Dex™ Hall effect sensors used in FP Series probes are highly symmetrical and uniform, resulting of inherently low zero-field offset voltages.
- 2 Special insulation used in the cable for optimum dielectric performance.
- 3 The advanced sensor excitation “spinning” technique progressively switches between different measurement configurations.
- 4 An onboard algorithm combines the sequential Hall voltage readings in a way that eliminates any offsets due to misalignment and thermoelectric effects. This method also reduces flicker noise, meaning that readings are both more accurate and more precise.

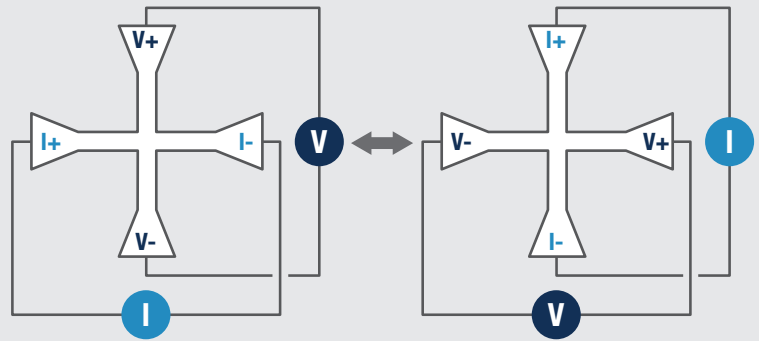

This means there is never a need to “zero” the probe before making a measurement. TruZero™ technology allows fast, worry-free, and always accurate measurements.

Note: periodic recalibration of probe and teslameter is still required to maintain an accurate conversion from Hall voltage to a field value. Not all errors can be removed completely with TruZero. Very small residual errors, much smaller than Earth field, may remain.

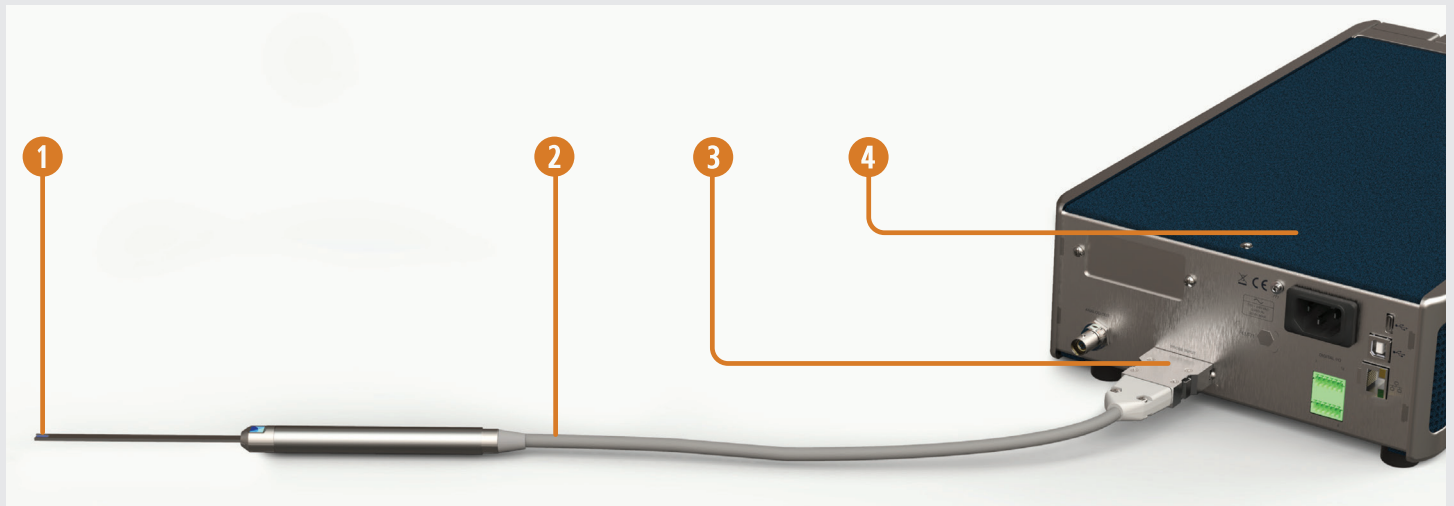

TruZero™ demonstration

An experiment was conducted to observe the qualitative benefit delivered by TruZero technology.

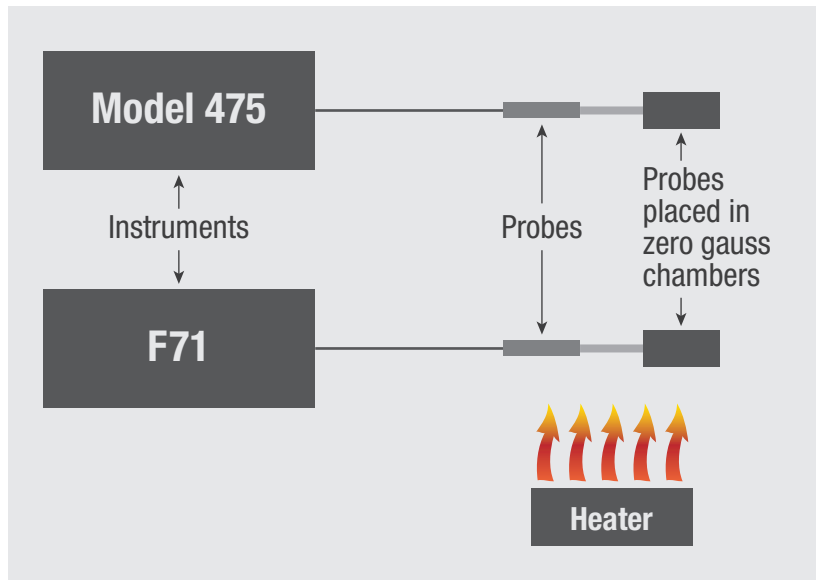

Experiment setup

- Model 475 and F71 placed in a temperature controlled room.
- Probes placed in zero gauss chambers where magnetic field is practically zero.
- 475 zeroed at the beginning of the experiment.
- Temperature cycled over multiple hours.

Outcomes

F71

- Very slight zero-offset drift with temperature
- No apparent drift with time
- Measurement resolution measured in nT

475

- More significant zero-offset drift with temperature
- Noticeable drift over several hours
- Measurement resolution measured in μT

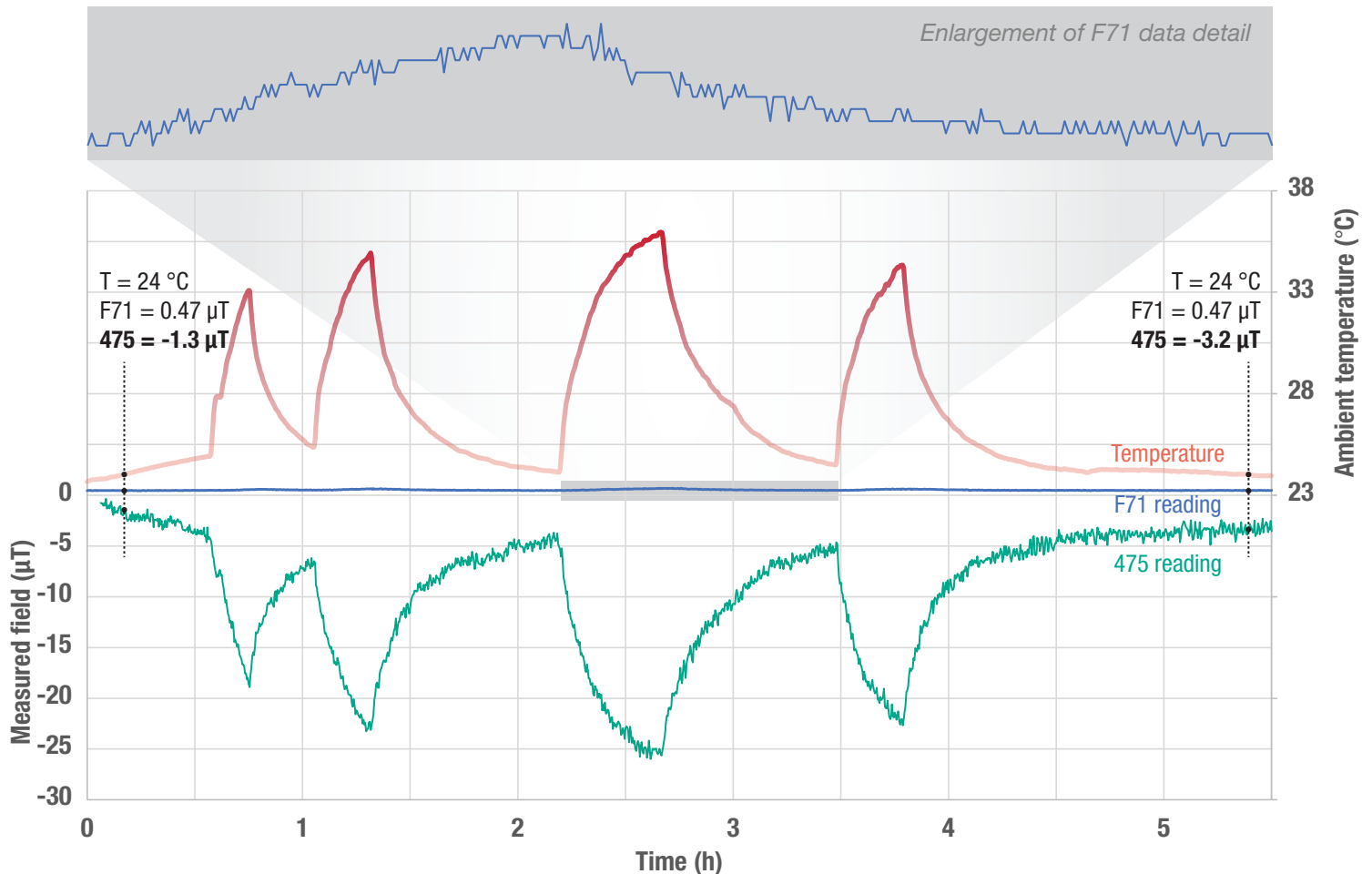

Integrate conveniently

Start taking measurements sooner

Lengthy warm-up times of 30 minutes or more are recommended for many teslameters and gaussmeters in order to stabilize internal temperatures.

The F71 and F41 teslameters use high-stability components with low temperature coefficients, eliminating warm-up time. Accurate readings can be taken instantly with these teslameters, removing one more variable to consider when taking field measurements.

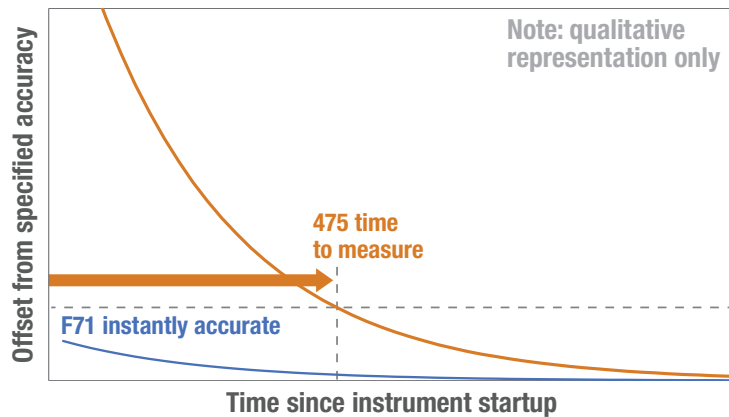

A single connector you can use without looking

The F71 multi-axis teslameter reaches its full potential when reading a 3-axis probe, delivering full vector field measurements. Connecting a probe like this should be quick and easy, which lead us to select our new probe connector.

- *Just one connector per probe*—previous implementations used separate connectors for each axis, requiring the user to pay special attention when connecting each of the 3 axes to their appropriate inputs. The new connector is used on both single and multi-axis probes, making it easier than ever to switch between probes.

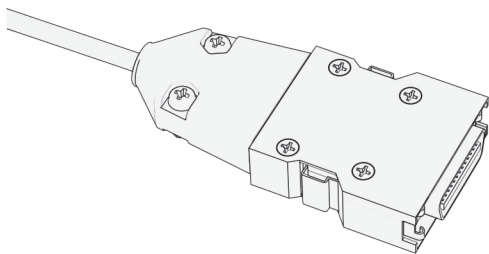

- *New latching mechanism*—allows quick and easy connection of a probe to the teslameter. The latches hold the connector securely in place without requiring thumb screws. When swapping probes, the quick-release mechanism allows you to switch probes reliably in just seconds.

System integration

The F41 and F71 teslameter use the same 2U half-rack chassis as other Lake Shore XIP instruments, with several mounting options for standard 19-inch racks:

- Single Lake Shore XIP instrument with adjacent blank panel
- Two adjacent Lake Shore XIP instruments
- Single Lake Shore instrument next to 3rd party 2U ½ rack instrument with common mounting screws

Fixture-friendly probes

Specifically designed for scenarios where fixturing the probe is required to achieve repeatable measurements.



- Machined aluminum mounting block for a solid non-deforming surface
- Locating pin holes allow for precise alignment of the probe
- Easily held in place with just two screws
- Drawings and CAD models publicly available, making integration with your hardware quick and easy, while minimizing the risk of design error.

Probe customizations welcomed

If your application requires something different, Lake Shore may be able to design a probe to fit your exact needs. FP Series probes are all manufactured in our Ohio facility with engineering staff onsite ready to support your application. Contact your local sales representative today to start the conversation.

Teslameter specifications

Input overview

Inputs

	F41 single-axis	F71 multi-axis
Number of measurement inputs	1	3
Number of physical connectors	1	
Connector type	26-pin mini D-sub	
Supported probes/sensors	Single-axis probes and single-axis plug-and-play sensors	Single-axis probes and single-axis plug-and-play sensors, plus multi-axis probes
Probes/sensors NOT supported	400 Series gaussmeter probes, and 2Dex, InAs, and GaAs loose sensors	

Ranges

	Autorange	35 mT (350 G)	350 mT (3.5 kG)	3.5 T (35 kG)	35 T (350 kG)
Standard	Yes	2 mA drive	2 mA drive	2 mA drive	0.2 mA drive
Cryogenic	Yes	No	0.2 mA drive	0.2 mA drive	0.2 mA drive

Software features

Available measurement readings

	Frequency range	Probe/sensor	DC component	AC RMS	AC peak-values	Frequency
DC mode	DC only	Single-axis	Yes	—	—	—
		3-axis	Yes (X, Y, Z, magnitude)	—	—	—
AC mode	DC to 550 Hz*	Single-axis	Yes	Yes	Yes	Yes
		3-axis	Yes (X, Y, Z, magnitude)	Yes (X, Y, Z, magnitude)	Yes (X, Y, Z, magnitude)	Yes (largest amplitude signal)
High frequency mode	1.7 Hz to 75 kHz*	Single-axis	—	Yes	Yes	Yes
		3-axis	—	Yes (X, Y, Z, magnitude)	Yes (X, Y, Z, magnitude)	Yes (largest amplitude signal)

*Frequency range defined as -3 dB point. See frequency specification for detailed information of instrument roll-off.

Relative values

	Single-axis probe/sensor	3-axis probe/sensor
DC mode	Field reading	Vector magnitude reading
AC mode	RMS reading	RMS of vector magnitude reading
High frequency mode	RMS reading	RMS of vector magnitude reading

Maximum hold

	DC measurement mode	AC measurement mode	High frequency mode
F41 single-axis	Field reading	RMS reading	RMS reading
F71 multi-axis	Magnitude readings	RMS reading of magnitude	RMS reading of magnitude

Maximum value Closest value to +∞

Minimum value Closest value to -∞

Max hold reset Reset max and min values at the same time or separately

Performance specifications

All specifications have a minimum confidence interval of 95% with a test uncertainty ratio of 4:1. Specifications are defined as 1 year after calibration with an instrument environment within ±5 °C of calibration. Temperature coefficient of ±0.002% of rdg/°C beyond ±5 °C of instrument calibration temperature applies to all accuracy specifications. Instruments are typically calibrated at an ambient temperature of 22 °C. The exact temperature can be found through the front panel of the instrument.

DC field measurement performance

System absolute measurement accuracy*

Accuracy of the reported field measurement.

	Individual axes (single-axis, X, Y, Z)	3-axis magnitude
Standard		
35 T (350 kG) range	±0.2% of rdg	±0.40% of rdg
3.5 T (35 kG) range	±0.15% of rdg	±0.30% of rdg
350 mT (3.5 kG) range	±0.15% of rdg	±0.30% of rdg
35 mT (350 G) range	±0.15% of rdg	±0.30% of rdg
Cryogenic		
35 T (350 kG) range	±0.2% of rdg	±0.40% of rdg
3.5 T (35 kG) range	±0.2% of rdg	±0.40% of rdg
350 mT (3.5 kG) range	±0.2% of rdg	±0.40% of rdg

*Probes calibrated to 2.5 T minimum and extrapolated to 35 T. Accuracy of flexible stem probes (FP-2X-250-TF15) limited to ±1.5% for all ranges and modes.

System measurement noise

Typical RMS measurement noise at zero field (teslameter and probe both contribute to measured noise, a realistic representation of measurement performance).

	Averaging window			
	10 ms	200 ms (default)	1 s	10 s
Standard				
35 T (350 kG) range	300 µT (3 G)	70 µT (700 mG)	30 µT (300 mG)	10 µT (100 mG)
3.5 T (35 kG) range	6 µT (60 mG)	1.2 µT (12 mG)	0.6 µT (6 mG)	0.17 µT (1.7 mG)
350 mT (3.5 kG) range	0.7 µT (7 mG)	0.16 µT (1.6 mG)	0.07 µT (0.7 mG)	0.03 µT (0.3 mG)
35 mT (350 G) range	0.5 µT (5 mG)	0.12 µT (1.2 mG)	0.05 µT (0.5 mG)	0.02 µT (0.2 mG)
Cryogenic				
35 T (350 kG) range	300 µT (3 G)	70 µT (700 mG)	0.05 µT (0.5 mG)	0.02 µT (0.2 mG)
3.5 T (35 kG) range	38 µT (380 mG)	8.5 µT (85 mG)	3.8 µT (38 mG)	1.2 µT (12 mG)
350 mT (3.5 kG) range	4.4 µT (44 mG)	1 µT (10 mG)	0.44 µT (4.4 mG)	0.14 µT (1.4 mG)

TruZero™ residual offset

Remaining detectable measurement offset (observed at zero field and expected to be present at higher fields as well)

	Individual axes (single-axis, X, Y, Z)	3-axis magnitude
Offset within ±5 °C of probe calibration temperature	±3.5 µT (±35 mG)	±7 µT (±70 mG)
Typical temperature coefficient beyond ±5 °C of probe calibration temperature	±0.3 µT/°C (±3 mG/°C)	±0.6 µT/°C (±6 mG/°C)

Quantum Hall effect additional uncertainty

When operating at high field at cryogenic temperatures, the Shubnikov-De Hass effect causes small oscillations in the effective Hall sensor sensitivity. The following plot outlines the additional uncertainty values that should be expected.

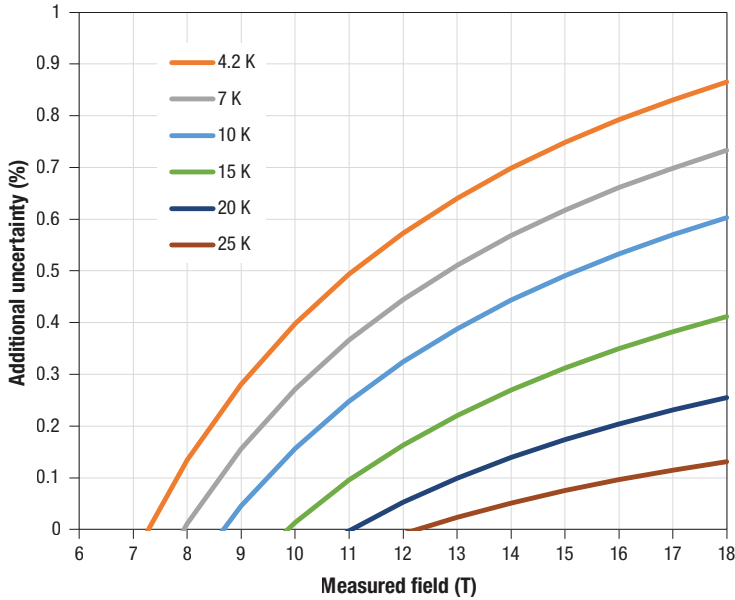

AC field measurement performance

AC mode bandwidth

AC mode cut-off frequency 550 Hz (-3 dB)
60 Hz (-0.2%)

Teslameter frequency response: AC mode

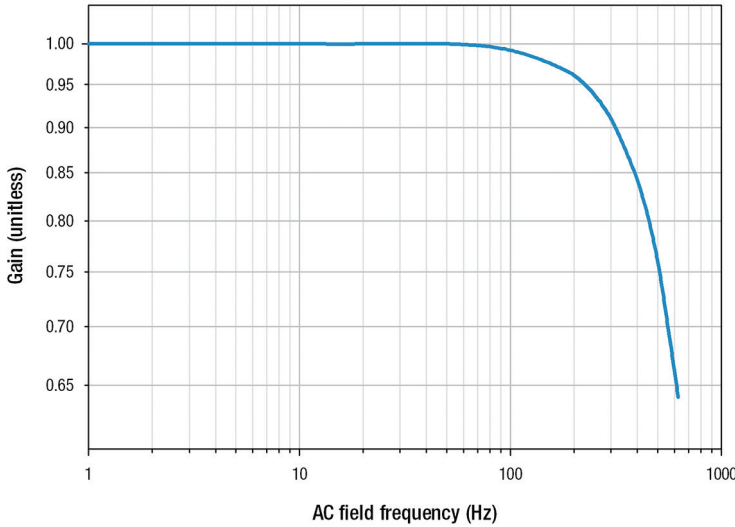

AC mode accuracy

Accuracy of the reported field measurement at frequencies within the flat response portion of the instrument frequency response curve.

	Individual axes (single-axis, X, Y, Z)	3-axis magnitude
RMS	±0.25% of reading ±0.05% of range	±0.5% of reading ±0.1% of range
Peak to peak	±0.55% of reading ±0.2% of range	Reading not present on instrument

High frequency mode measurement performance

High frequency mode passband 1.7 Hz to 75 kHz (-3 dB point)
20 Hz to 7 kHz (-0.2%)

Teslameter frequency response: high frequency mode

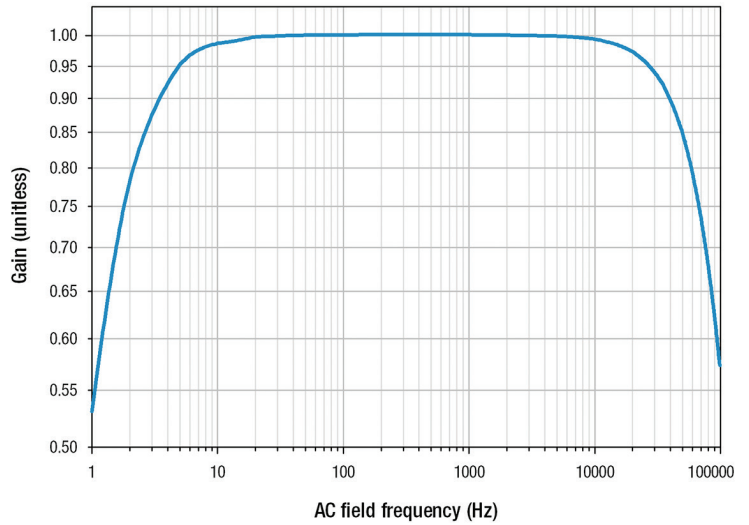

High frequency mode accuracy

Accuracy of the reported field measurement at frequencies within the flat response portion of the instrument frequency response curve.

	Individual axes (single-axis, X, Y, Z)	3-axis magnitude
RMS	±0.5% of reading ±0.5% of range	±1% of reading ±1% of range
Peak to peak	±2% of reading ±2% of range	Reading not present on instrument

Frequency detection

Frequency detection counter accuracy: ±1% of frequency ±1 Hz for a periodic wave faster than 1 Hz and RMS value greater than 1% of range

Temperature compensation

Temperature compensation of field

Sensor/probe temperature-dependent field measurement error — we have characterized the temperature dependence of sensitivity for our Hall sensors and apply a correction factor to compensate. The residual error listed below reflects the variability that exists from sensor to sensor.

	Temperature range			
	-273 °C to 0 °C	0 °C to 35 °C	35 °C to 60 °C	60 °C to 90 °C
Compensation: on	±1.5%	±0.02%	±0.1%	±0.5%
Compensation: off	See temperature coefficient of sensitivity data for loose 2Dex sensors			

Temperature compensation sources: Embedded probe sensor, manual entry (front panel), manual entry (external communication), none (compensation off)

Temperature compensation range: Probe dependent (see probe specifications for details)

Analog output

	Mode	Function	Channels/readings available (non-concurrent)
Raw modes	DC	Diagnostic only	X, Y, Z
	AC	Diagnostic only	X, Y, Z
	High frequency	Analog representation of waveform (pulse, etc.)	X, Y, Z
Corrected modes	DC	Analog representation of field values	X, Y, Z, vector magnitude
	AC	Analog representation of RMS field values	X, Y, Z, vector magnitude
	High frequency	Analog representation of RMS field values	X, Y, Z, vector magnitude

Limits:	±12.5 V possible during overload
Raw signal source:	Analog amplified Hall voltage
Raw signal accuracy:	±1% of amplified Hall voltage value ±50 mV
Corrected output source:	DAC generated voltage based on field reading
Corrected output range:	±3.5 V = full range
Corrected output accuracy:	±1% of front panel measurement
Corrected output update rate:	2 kHz

Field control option card

Control types:	Closed loop (PI) or open loop
Closed loop control technology:	Proprietary composite DAC, ensures control circuit does not limit resolution
Features:	Setpoint, setpoint ramping
Full scale voltage output:	±10 V
Control resolution:	<0.1 µT (<1 mG)*
Protections:	Configurable maximum slew rate, configurable voltage limit
Open loop voltage accuracy:	±1% of full scale

* Specified value applies for the 350 mT range with 10 second averaging. Specification limited by measurement noise. Control resolution for a particular configuration is double the specified system noise.

Digital I/O

Inputs

Number of independent inputs	2
Input isolation	Optical
Maximum low-level input voltage	1 V
Minimum high-level input voltage	4 V
Safe input voltage range	-5 V to 35 V

Outputs

Number of relays	2
Relay type	Solid state
Digital output relay maximum current	2 A
Digital output relay maximum voltage	35 V

Environment

Instrument operating environment	23 °C ±5 °C and <70% relative humidity non-condensing at rated accuracy; -20 °C to 70 °C and <90% relative humidity non-condensing at reduced accuracy
Instrument max field exposure	10 mT (100 G) DC, 1 mT (10 G) RMS

Communication

Protocols

Each protocol is supported on all interfaces.

	Function
SCPI commands	Native communication method with instrument
Python driver	Simplifies connection and operation with Python
LabVIEW™ driver	Add teslameter to LabVIEW™-controlled systems
IVI.NET driver	Easier integration with test and measure instruments

USB host

Type	USB 3.0, mass storage class (MSC) device
Function	Firmware updates, flash drive support
Location	Rear panel
Connector	C-type USB connector

USB device

Type	USB 2.0
Function	Emulates a standard RS-232 serial port
Protocol	Standard commands for programmable instruments (SCPI)
Baud rate	115,200
Connector	B-type USB connector
Software support	LabVIEW™ and IVI.NET drivers (see www.lakeshore.com)

Ethernet

Function	TCP/IP command and control, mobile app (in development)
App layer protocol	Standard commands for programmable instruments (SCPI)
Connector	RJ-45
Speed	1 Gb/s
Software support	LabVIEW™ and IVI.NET drivers (see www.lakeshore.com)

Display

Display update rate	5 rdg/s
Display	5 in capacitive touch, color 800 × 480 with LED backlight

General

Operating conditions	23 °C ±5 °C, <70% relative humidity non-condensing at rated accuracy; -20 °C to 70 °C, <90% relative humidity non-condensing at reduced accuracy
Power requirement	100 V to 240 V (universal input), 50 to 60 Hz, 30 VA
Size	217 mm W × 87 mm H × 317 mm D (8.5 in × 3.4 in × 14.5 in), half rack
Weight	3.2 kg (7 lb)
Approval	CE mark
Warm-up time	Ready on boot
Power consumption	35 W maximum

What happened to “gaussmeter?”

In 1992 Lake Shore made a splash in the magnetic measurement space with its first gaussmeter, the Model 450 single-axis gaussmeter.

In the decades since, Lake Shore has released 9 other gaussmeter models, ranging from battery-powered handhelds through to full-rack multi-axis units. The word “gaussmeter” has been used to describe them all.

As units of magnetic flux density (B), gauss and tesla have long been used to characterize magnetic forces and are related to one another by a factor of 10,000:

	Gauss	Tesla
System of units	cgs (centimeter-gram-second)	SI (meter-kilogram-second)
Definition	1 Mx/cm ²	1 Wb/m ²
Equivalent	0.0001 T (100 μT)	10,000 G (10 kG)

The preference to use gauss stems from its relationship with magnetic field strength (H), which in cgs units is the oersted and has the extremely simple relationship of 1 gauss = 1 oersted in free space, which was much easier to work with than the 4π component in the SI conversion process.

However, cgs units have since been deprecated by SI units, with tesla now being the official worldwide unit for magnetic flux density. In the US, this was signed into law in 1998 and has since been codified by NIST Special Publication 1038.

Given Lake Shore’s dedication to advancing science, we felt it was time to shed the product name that ties us to an old measurement scheme and move to one that reflects the state of modern measurements. The confusing part may come from us leaving our previous generation of products as gaussmeters. Over time these instruments, along with their names will be retired, but until that happens we plan to continue referring to them with the names they were originally given.

We encourage everyone to begin transitioning to the use of “teslameter” to describe these products. However, we understand that old habits can be difficult to break, so we promise we can stay friends even if you use gaussmeter and teslameter interchangeably. Because in the end, it doesn’t matter what you call them, as long as they are a pleasure to use and allow you to take the measurements you need.



Ordering information

F41/F71 teslameters

F41	F41 single-axis teslameter
F71	F71 multi-axis teslameter

Accessories

CAL-F41-CERT	F41 teslameter recalibration with certificate
CAL-F41-DATA	F41 teslameter recalibration with certificate and data
CAL-F71-CERT	F71 teslameter recalibration with certificate
CAL-F71-DATA	F71 teslameter recalibration with certificate and data

Collaborator Program

The new Lake Shore teslameters are amazing instruments, but we're not done yet. Our firmware development team will continue to add and improve software features, but we want your help. The Collaborator Program allows you to provide input and help us prioritize future development. Engage with us as often as you like, or just enjoy the free updates as features are added.

What you need to know about the program:

- Teslameter hardware is complete, with future optional updates applying to software and firmware only. This means that at the end of the program, all Collaborator Program teslameters will have equivalent functionality to new teslameters.
- A discount of 15% is applied to the price of both teslameter models for the duration of the program.
- Downloading software updates requires an Ethernet connection to the internet.
- Product feedback can be provided on <http://forums.lakeshore.com>, with development updates being posted there as well.



Not ready to purchase one of the new teslameters, but interested in following along with development? Sign up to receive notifications at www.lakeshore.com/teslameters.

Give us your opinions on the priority and implementation of features such as:

- Cryogenic operating mode
- Closed loop field control (via purchased option card)
- High-speed data capture (100/s)
- Additional programming libraries
- Pulse capture (targeting magnetizer applications)
- Signal filtering
- Data logging
- Onboard chart recorder
- Quality control features such as pass/fail and alarms
- Audible peak field detector
- DIY calibrations
- Mobile application support

Note: this is not an extensive list. Features will be added, removed and reprioritized with input from the community.

FP Series Hall probes

Features

- Wide field range—suited for everything from earth-field to the world's strongest electromagnets
- 2Dex™ sensors with tiny active area of just 0.1 mm² for more precise measurements
- Temperature and linearity (field) compensation are built-in
- Versatile handle and stem options to suit numerous applications
- Ease of use features such as active area and polarity indicators
- Application-specific probe customization available



The FP Series probes make it easier than ever to integrate magnetic field measurement into your system. Take advantage of probes and sensors that really fit your application for optimum measurement results.

Lake Shore offers probes for every need, including 3-axis (vector), transverse, and axial models available in both handheld and fixture-mountable versions. Special cryogenic versions are also available.

If your application is unique, Lake Shore may be able to design a probe to fit your exact needs. FP Series probes are all manufactured in our Ohio facility with engineering staff on site ready to support your application. Contact your local sales representative today to start the conversation.

FP Series probe availability

Transverse

Stem type	Stem material	Stem size	Form factor	Stock probes highlighted in yellow				Part number
				Stem Lengths (cm)				
Standard	Aluminum	1.55 × 4.57 mm	Handheld	5	15	30	—	FP-2X-250-TSXX
			Mountable	5	15	30	—	FP-2X-250-TSXXM
Flexible-thin	PCB	1.14 × 3.53 mm	Handheld	—	15	—	—	FP-2X-250-TF15
			Mountable	—	15	—	—	FP-2X-250-TF15M
Cryogenic	Stainless steel	4.75 mm diameter	Handheld	—	—	30	150	FP-2X-250-TCXXX

Axial

Stem type	Stem material	Stem size	Form factor	Stem Lengths (cm)				Part number
				Stem Lengths (cm)				
Standard	Aluminum	2 mm diameter	Handheld	5	15	30	—	FP-2X-250-ASXX
			Mountable	5	15	30	—	FP-2X-250-ASXXM
Cryogenic	Stainless steel	4.75 mm diameter	Handheld	—	—	30	150	FP-2X-250-ACXXX

3-axis

Stem type	Stem material	Stem size	Form factor	Stem Lengths (cm)				Part number
				Stem Lengths (cm)				
Standard	Aluminum	4 × 4 mm	Handheld	5	15	30	—	FP-2X-250-ZSXX
			Mountable	5	15	30	—	FP-2X-250-ZSXXM

The mountable handle has locating pin holes for precise and repeatable probe alignment.

CAD files for the mounting fixture template are available free in the Downloads section of the teslameter pages on our website.

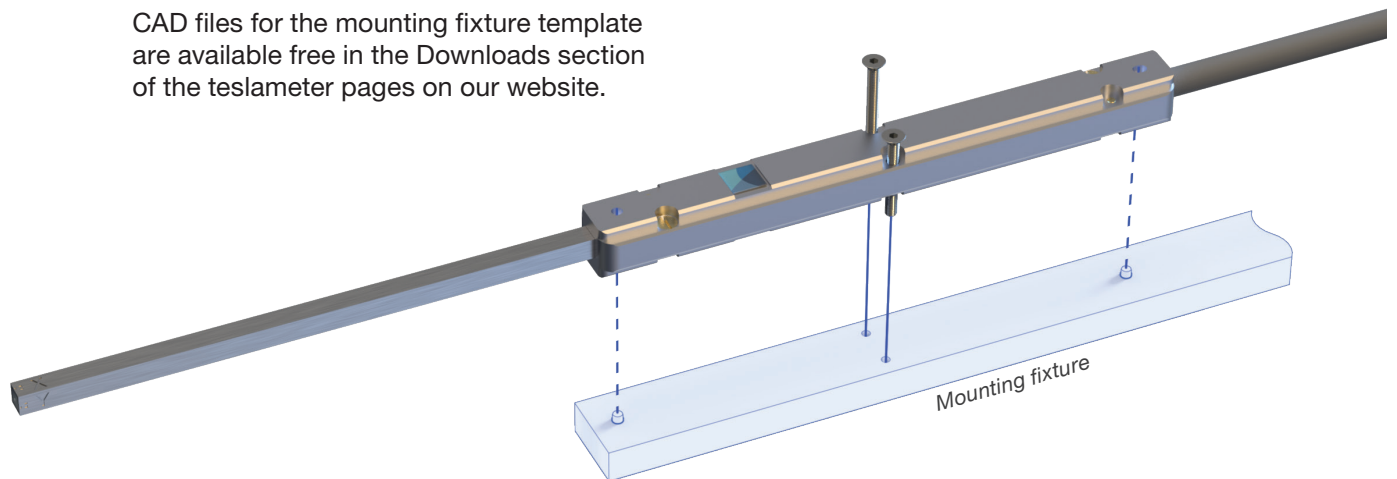

Probe configuration options

Customize your probe using the range of available options to match your application.

FP-aa-bbb-cdee(f)(-gg)

Sensor

2X-250	2Dex™
--------	-------

Orientation

Z	3-axis
T	Transverse (single-axis)
A	Axial (single-axis)

Stem type

S	Standard
F	Flexible-thin
C	Cryogenic

Stem length

05	5 cm (2 in)
15	15 cm (6 in)
30	30 cm (12 in)
150	150 cm (60 in)

Special handle (optional)

	Handheld (default)
M	Mountable

Additional cable length (optional)

	2 m (6 ft) (default)
6	6 m (20 ft)
15	15 m (50 ft)

Sensor

2X-250	2Dex™
--------	-------

2Dex™ sensors are currently the only sensor types currently available with FP Series probes. These are the first probes to feature 2Dex sensors which offer a great balance of sensitivity, linearity, stability and ruggedness. These sensors set the new standard for the majority of field measurement applications.

Orientation

Hall sensors are inherently directional, so the anticipated field direction will guide the selection of probe orientation.

Z	3-axis
---	--------

Multiple sensors are placed to measure three orthogonal field vectors, allowing the measurement of both the overall field value and direction. This is particularly useful in several scenarios:

- Complex fields where the field direction is not known or changing over time
- Quick handheld measurements
- Field mapping of a volume

The three individual sensors don't occupy the exact same location, meaning the three separate measurements are for slightly different positions in space. This results in the specification of an active volume, as opposed to an active area for single-axis probe variants. These probes can be identified by their square stem cross-section.

3-axis probes are only available with a standard stem up to 30 cm in length.

T	Transverse (single-axis)
---	--------------------------

The sensor is positioned to measure fields running perpendicularly through the probe stem. This is most useful for measuring fields inside magnet gaps. These probes are easily identified by their flattened rectangular stem.

A	Axial (single-axis)
---	---------------------

The sensor is placed very near to the tip of the probe and aligned to measure fields normal to the tip of the probe. This orientation is necessary when measuring inside solenoids, and can be useful for measuring fields at magnet poles due to the increased ease of alignment and fine adjustment.

Axial probes are not offered with a flexible-thin stem.

Stem type

The sensor/s are housed in stem types suited for various applications. Where possible, active area locations are marked on the stems.

S Standard

The general-purpose stem options offer an excellent balance of size and strength. Constructed from extruded and precision machined aluminum, these stems will be the superior choice in most situations.

F Flexible-thin

This stem type is currently only available as a transverse orientation option at a fixed stem length. The surrounding aluminum stem of the standard probe is removed, exposing the PCB and sensor element. This results in a somewhat flexible stem that is also thinner than the standard offering, making it the best probe for measuring in very thin magnet gaps. It is possible to snap the PCB stem of this probe with excessive bending, so this should be minimized to prolong the life of the probe.

This stem also features a helpful ruler printed directly on the PCB. Useful in determining just how far the probe has been inserted into the magnet gap.

C Cryogenic

Ultra-low temperature applications require a more drastic overhaul of the probe stem:

- Non-magnetic stainless-steel alloy minimizes heat leak, while providing strength
- Greater stem lengths offered as standard to reach into the cryogenic environment
- Vented at the tip to allow cryogenics to escape safely
- Cryogenic 2Dex™ sensors used in place of standard solution

Due to the increased sensor size used in these probes, 3-axis probes with very small active volumes are not possible. Contact us if you have an application that requires multi-axis cryogenic measurements to discuss options.

Stem length

FP Series probes come in various lengths to suit your application.

	5 cm (~2 in)	15 cm (~6 in)	30 cm (~12 in)	150 cm (~60 in)
	05	15	30	150
Standard	■	■	■	
Flexible		■		
Cryogenic			■	■

If your application requires a non-standard stem solution, please contact us to discuss options.

Special handle (optional)

Both handle options include polarity indicators when ordered with a transverse orientation, making it easy to quickly determine whether a magnet polarity has been switched, or if the probe is just being held incorrectly.

Handheld (default)

The default handle configuration is designed to be a comfortable and functional handheld solution with an anodized aluminum grip for a solid and long-lasting grip surface.

M Mountable

In situations where probe fixturing is required to achieve repeatable measurements, the mountable form factor features a flat machined aluminum surface. It also includes locating pinholes for precise probe alignment and is easily held in place with just two screws.

Publicly available drawings and CAD models for this handle will make integration with your hardware quick and easy while minimizing the risk of a design error. These handles are available with standard and flexible stem choices.

Cryogenic probes are not available with a mountable stem.

Additional cable length (optional)

2 m (6 ft)	6 m (15 ft)	15 m (50 ft)
	6	15

The probe cable and connector have also received close attention to optimize performance and usability. The shielded cable was selected to be as thin and light as possible, while using a special insulation that is both recyclable and forms a part of the TruZero™ technology that allows the probes to operate without needing to zero.

The connector makes use of the compact Micro-D standard to support all connections required for a 3-axis probe in a reasonably sized package. Both single and multi-axis probes use this connector, so there is no need to pay special attention to making individual axis connections as is the case for other multi-connector solutions. A user-friendly latching mechanism means swapping probes is fast and trouble free and can be accomplished in just a few seconds.

Calibration data for the probe is stored inside the connector, allowing for fast and simple probe swapping. The teslameter configures itself automatically each time a probe is connected.

Most probes come with a 2 m (6 ft) cable by default, but can be customized with either a 6 m (20 ft) or 15 m (50 ft) cable. This is particularly useful for very large fields, as the teslameter unit itself should not be exposed to strong fields.

Note: Cryogenic probes with 150 cm stems are not available with the 2 m cable option. Please select the 6 or 15 m option.

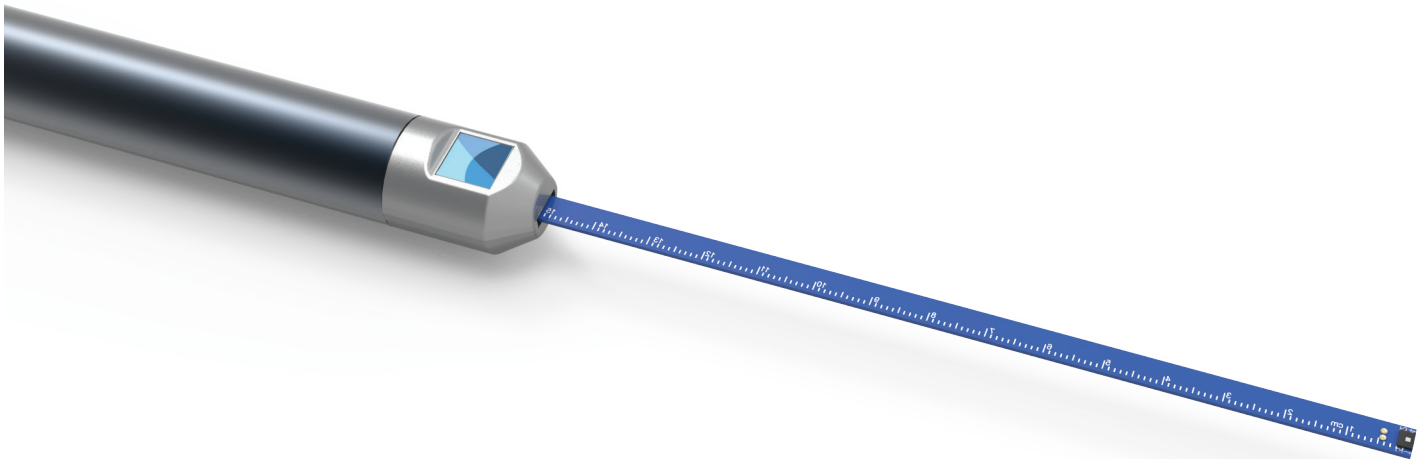

FP Series probe specifications

Sensor type

	Sensor	Description	Active area
2X-250	2Dex™ 2X-250	2Dex™ standard sensor	0.1 mm ²

Temperature compensation

	Built-in thermistor	Temperature range
Standard	Yes	0 °C to 90 °C
Flexible-thin	Yes	0 °C to 90 °C
Cryogenic	No	4 K to 363 K using external temperature data

Stem material

	3-axis	Transverse	Axial
Standard	Anodized aluminum tube with a 4 mm square cross section	Anodized aluminum tube with a 1.55 mm maximum thickness by 4.57 ±0.13 mm rectangular cross section	Anodized aluminum tube with a 2 mm diameter circular cross section
Flexible-thin	NA	FR-4 PCB 1.14 mm maximum thickness by 3.53 mm	NA
Cryogenic	NA	316 stainless steel tube with 4.75 +0.15/-0.11 mm diameter circular cross section	316 stainless steel tube with 4.75 +0.15/-0.11 mm diameter circular cross section

Stem length: Distance from tip of sensor to beginning of handle

*Cryogenic probes are suitable for use at cryogenic temperatures, but may be damaged with fast thermal cycling. Allow all condensation to fully evaporate from probe before resubmerging into cryogen to avoid damage. Probes damaged by fast thermal cycling are not covered by the product warranty.

Stem operating temperature range

	3-axis	Transverse	Axial
Standard	0 °C to 90 °C	0 °C to 90 °C	0 °C to 90 °C
Flexible-thin	NA	0 °C to 90 °C	NA
Cryogenic	NA	4 K to 363 K	4 K to 363 K

Handle

	Handheld (default)	Mountable
Length, including strain relief	138 mm	110 mm
Diameter	13 mm	NA
Thickness	NA	10 mm
Width	NA	12 mm
Material	ABS/polycarbonate blend with anodized aluminum grip	Machined aluminum with brass screws. Mountable to fixture using customer supplied M2 screws with 3.8 mm diameter socket head and 2 mm diameter alignment pins
Operating temperature range	0 °C to 80 °C	0 °C to 80 °C

Cable

	Single-axis	3-axis
Diameter	4 mm (0.17 in)	5.2 mm (0.21 in)
Bend radius	40 mm (1.57 in)	52 mm (2.05 in)
Operating temperature range	-40 °C to 80 °C	
Conductors	4 twisted-pair	14 twisted-pair
Cable shield	100%-coverage foil	100%-coverage foil
Cable insulation	Modified polyphenylene ether	
Connector	26-pin Mini-D with quick-release latch	

Axial probe (ASXX) typical frequency response

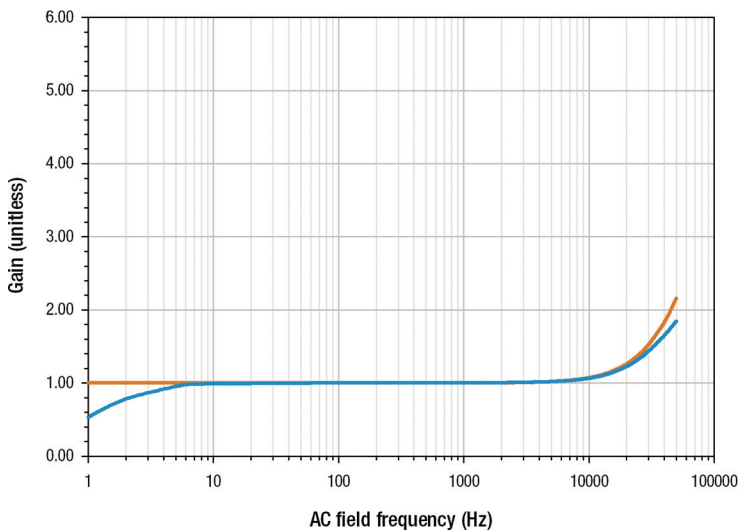

— Probe only
 — Teslameter and probe combined (HF mode)

Transverse probe (TSXX) typical frequency response

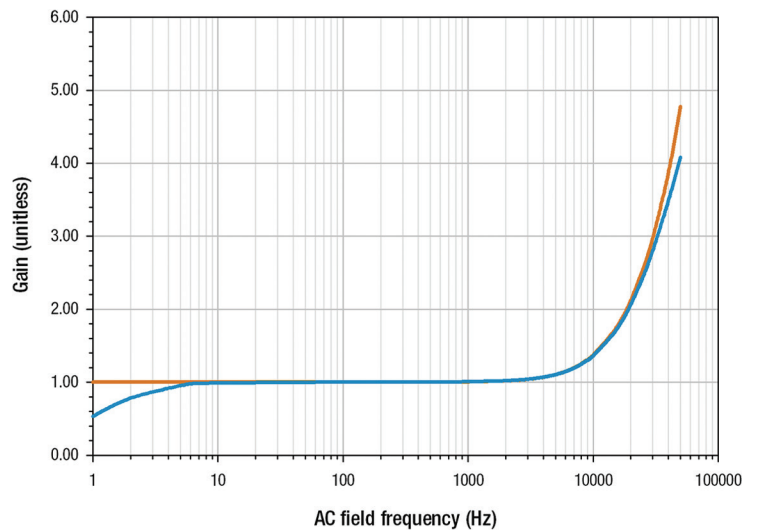

Probe active areas

Axial probe active area

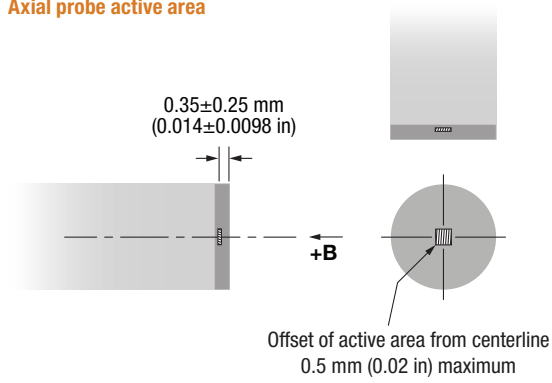

Transverse probe active area

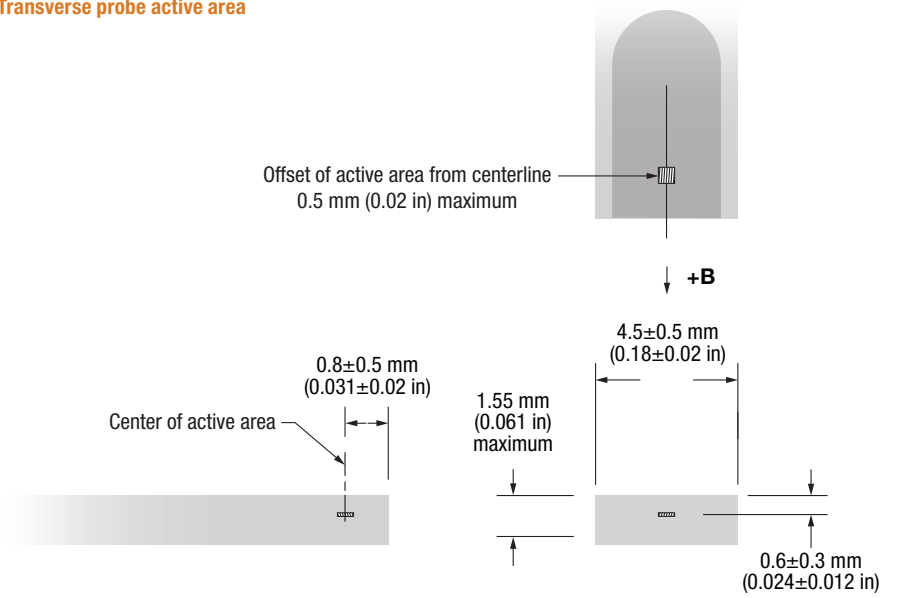

Flexible probe active area

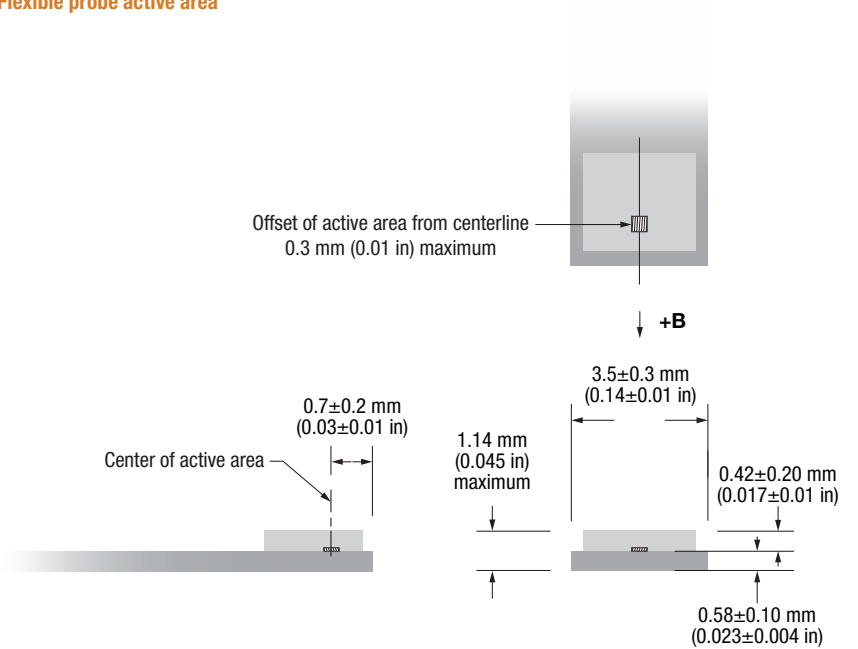

3-axis probe active area

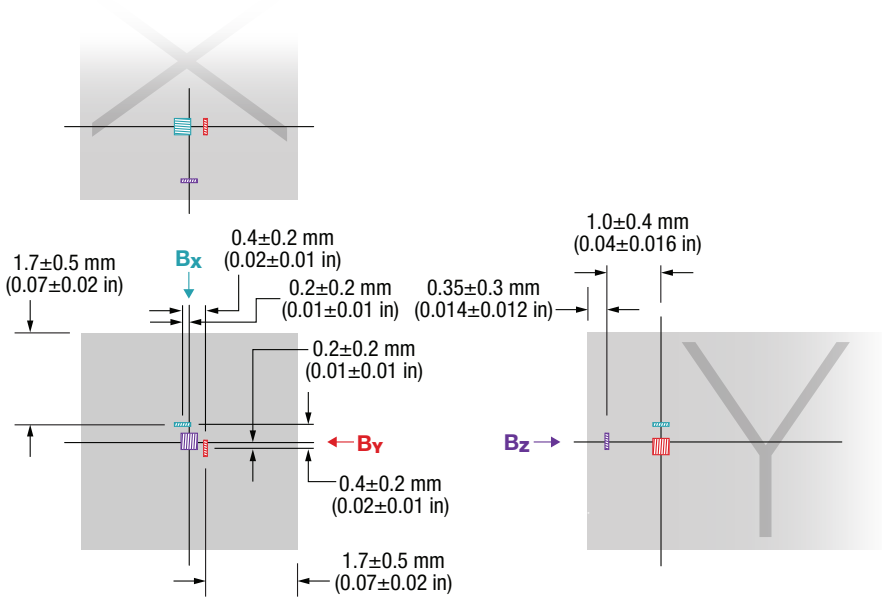

Cryogenic axial probe active area

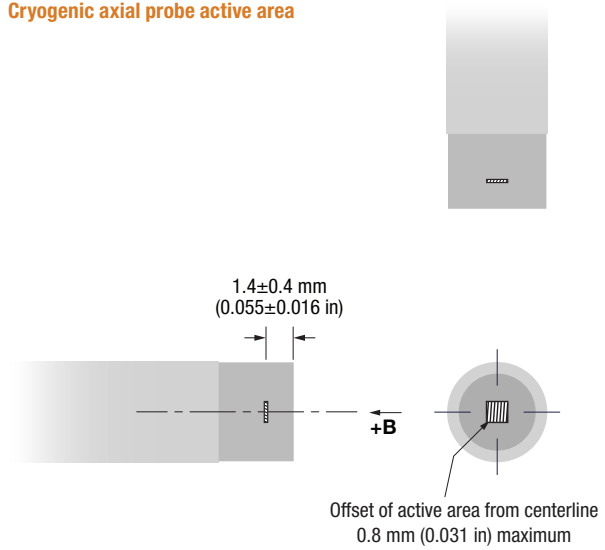

Cryogenic transverse probe active area

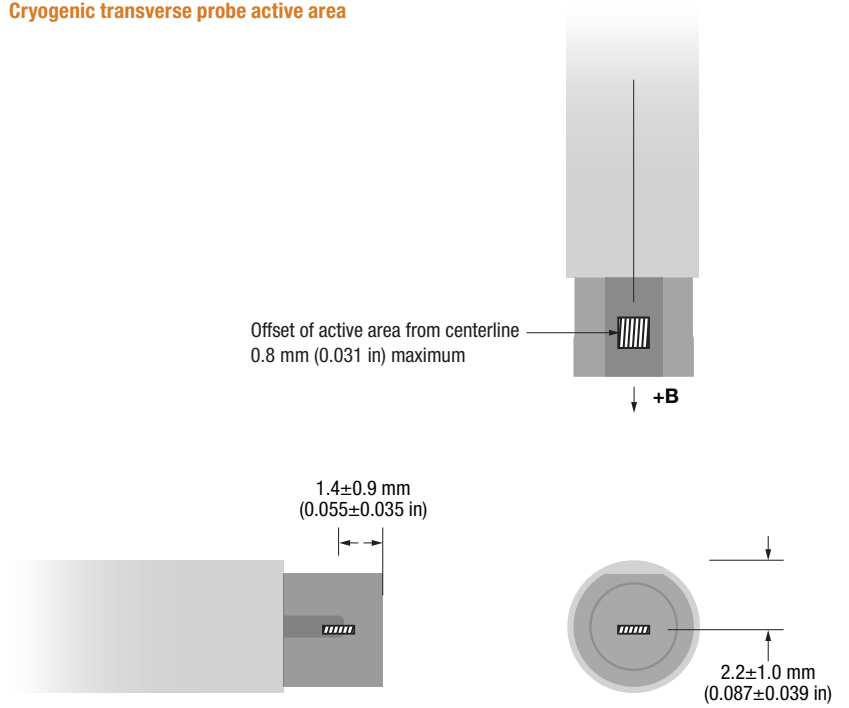

Copyright © Lake Shore Cryotronics, Inc. All rights reserved. Specifications are subject to change.

Lake Shore Cryotronics, the Lake Shore logo, the square graph logomark, and Cernox are registered trademarks of Lake Shore Cryotronics, Inc.

All other trade names referenced are the service marks, trademarks, or registered trademarks of their respective companies.

070821

Questions? Answers?

Visit <http://forums.lakeshore.com/> and become part of the conversation!



Lake Shore Cryotronics, Inc.
575 McCorkle Boulevard
Westerville, OH 43082 USA
Tel 614-891-2244
Fax 614-818-1600
e-mail info@lakeshore.com
www.lakeshore.com